

EXIT-1048 - Constant Power Outdoor-Rated Emergency LED Driver

BLEMSLP-CP-CW

Project:	
Type:	
Catalog #:	

STANDARD



ILLUMINATION

- Provides constant power output to the load during emergency mode operation.
- Can be operated as NORMALLY-ON, NORMALLY-OFF or SWITCHED LOAD.
- Ideal for use with canopy lights, garage lights and any outdoor fixture that needs emergency lighting.

ELECTRICAL

- Universal 120-277V, 50/60 Hz input.
- Charge/Power "ON" LED indicator light and push-to-test switch for mandated code compliance testing.
- Long-life, maintenance free, rechargeable NiCad battery.
- Output short/overcurrent protection: Electronic limiting, with normal operation resuming upon removal of fault.
- 90 minutes minimum emergency operating time over full temperature range.
- Output classification: Class 2 Compliant.
- Surge protection: Per C62.41 (TVS).
- Input overcurrent protection: Fusible link.
- 24 Hour maximum battery recharge time.

HOUSING

- Decorative, low profile, architectural design.
- Die-cast aluminum housing.
- Durable powder-coated bronze finish.
- Sealed and gasketed.

MOUNTING

- Suitable for installation as top, or side mount of the fixture.

ORDERING INFORMATION

Lumen output based on LED light source having efficacy of 160 lumens/watt. Actual output may vary depending on light source utilized.

Provides regulated power to 17.0 watts (2400 lumens)

MODEL	OUTPUT OPERATING RANGE		OUTPUT POWER	
	VOLTAGE (Vdc)	CURRENT (mAdc)	(Watts)	(Lumens)
BLEM-CP-CW	20-50	850-340	17.0	2400

WARRANTY/LISTING

- UL Classified for factory or field installation.
- Suitable for wet locations (-20°C - 50°C).
- 5 year warranty on all electronics and housing.
- Meets UL924, NFPA 101 Life Safety Code, NEC, OSHA, Local and State codes.
- Certified to CEC under Title 20 regulations.

DIMENSIONS

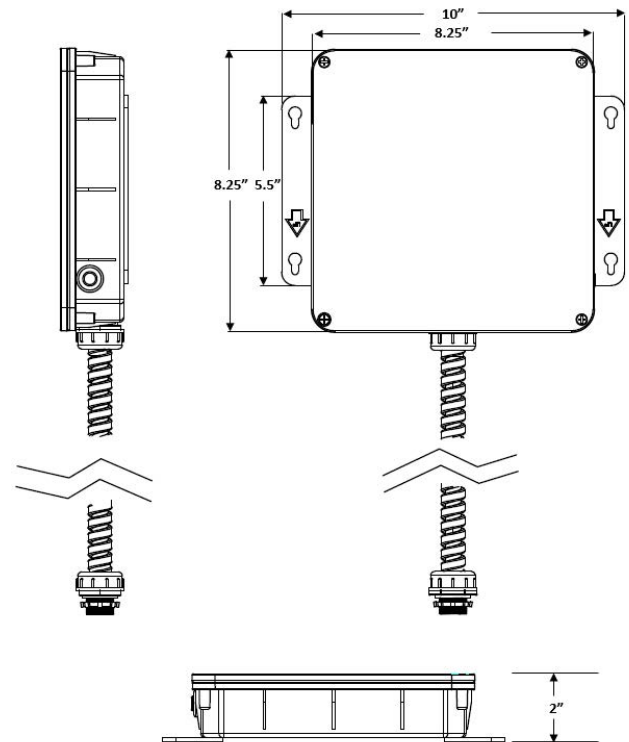

Project:	
Type:	
Catalog #:	

ELECTRICAL INFORMATION

MODEL	INPUT CURRENT (A)	INPUT POWER (W)
BLEM-CP-CW	0.11	7.9

WIRING DIAGRAM

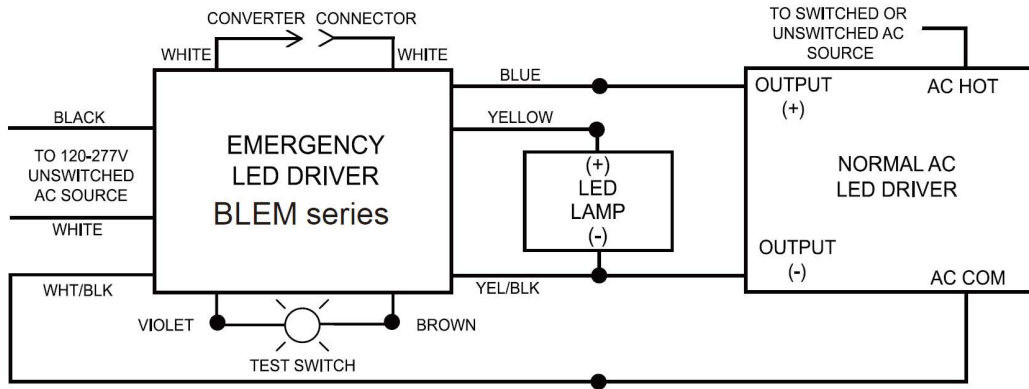

BLEM-CP-CW Series System Coordination Guidelines

These guidelines were developed to allow the lighting system Designer/Specifier to predict the operating performance levels of LED luminaires when powered by an electrically compatible BLEM-CP-CW Series model. It is ultimately the responsibility of the Designer/Specifier to insure that the as installed system delivers code-compliant path of egress illumination.

1) Determine Electrical Compatibility

- Verify that the Luminaire LED Driver, where applicable, is Class 2 compliant.
- Verify that the Luminaire LED Lamp(s) have an operating voltage between 20Vdc and 50Vdc range.
- Verify that the Luminaire LED Lamp(s) have a power rating equal to, or greater than 17 watts (emergency power rating of the BLEM-CP-CW driver).

2) Calculate Lumen Output During Emergency Operation

- Access luminaire data by logging onto Design Lites Consortium (www.designlights.org).
- Select "Search the DLC Qualified Product List" on the DLC homepage.
- Enter manufacturer name and P/N of luminaire under consideration in the "search by keyword" text window.
- Select "Search" tab to open the "Qualified Products List".
- Determine luminaire Lumens per Watt efficacy in "Rated Data" specifications.
- Multiply luminaire Lumens per Watt by 17 (output power of BLEM-CP-CW driver). This figure is the Lumens available from the luminaire during emergency operation.

3) Determine Suitability of Means of Egress Lighting Levels

- Using industry standard lighting design software, along with IES files for the luminaire under consideration, verify that the as installed available Lumens (as calculated in 2F above) are sufficient to meet Code-compliant path of egress illumination levels.

While the BLEM-CP-CW series has been found compliant with the requirements of UL Standard 924, it is ultimately the responsibility of the Designer/Specifier to ensure the as-installed system delivers code-compliant path of egress illumination in accordance with Federal, State or local municipal requirements.